



UTF53V10R Rear Trac Bar Instructions

F-53 Chassis with 20-22K GVW Rear Bar

Each installation may vary due to chassis manufacturing options and variations in design. The rod assembly may be installed in several different combinations, such as either front or rear of the supplied brackets as well as using different bracket holes. The important thing is to maintain clearance between your UltraTrac and any chassis component (moving and stationary) such as exhaust, vehicle frame, differential, or any other item which might interfere with the operation of this product.



Bolt Torque Specifications

Torque in Foot-Pounds for Inch Bolts

Bolt Size	Grade 5	Grade 8
1/4"	10	14
5/16"	19	29
3/8"	33	47
7/16"	54	78
1/2"	78	119
5/8"	154	230
3/4"	257	380

Bolt Torque Specifications

Torque in Foot-Pounds for Metric Bolts

Bolt Size	Grade 8.8	Grade 10.9
6MM	6	8
8MM	16	22
10MM	31	40
12MM	54	70
14MM	89	117
16MM	161	230
18MM	222	318

Bolt Torque Specifications

Torque in Foot-Pounds for Grade 5 U-Bolts

Bolt Size	Fine	Course
3/8"	21	18
7/16"	33	29
1/2"	52	45
5/8"	107	91
3/4"	190	165
7/8"	304	270

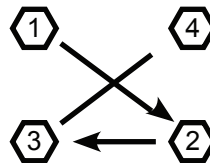

*Always tighten and torque u-bolts in a cross pattern sequence.

NOTICE

- Only a qualified mechanic using normal automotive tools and following all safety standards should perform the installation of this product.
- If the vehicle is equipped with air bags be sure that nothing interferes with the deployment of them.
- Be sure to use Loctite® Red on all bolts before tightening. Tighten all bolts according to the torque charts provided or to the manufacturer's torque specifications on OEM parts. If no manufacturer specifications can be found then use the torque charts provided.
- Dealer or installer be certain the user receives these instruction sheets.

UltraTrac

Steering and Handling Products

F-53 Chassis with 20-22K GVW Rear Bar

Tools Required

Torque Wrench
 3/4" Socket
 3/4" Wrench
 7/8" Socket
 1-1/16" Socket
 1-1/8" Wrench
 6" Drive Extension

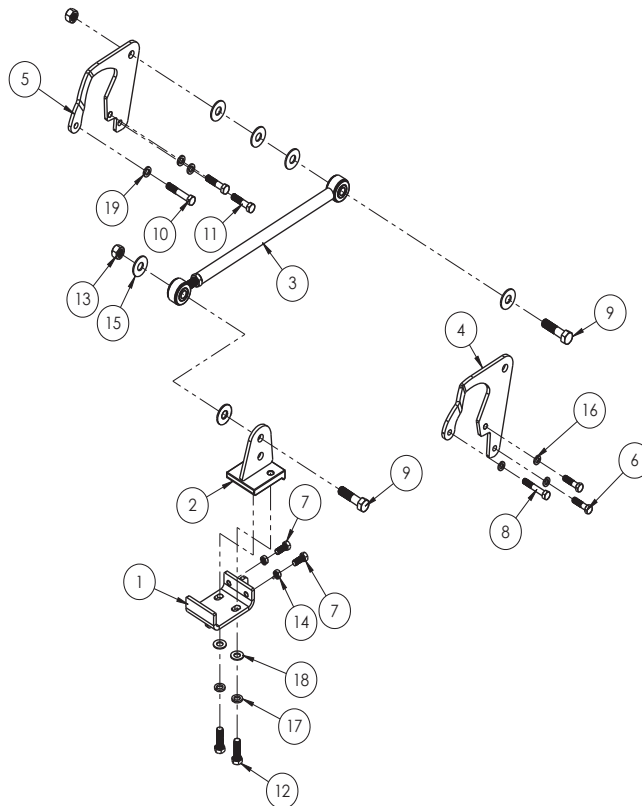

NOTE: There are two (2) axle brackets in this kit. One fits the 110/115 rear axle and one fits the 135/150 rear axle. Match the bracket to the bolt pattern and discard the bracket that does not fit.

Item No.	Part Number	Description	Qty.
1.....	61-6745.....	UTF53V10R Frame Bracket Weldment.....	1
2.....	61-6746.....	UTF53V10R Nut Plate Frame Bracket Weldment.....	1
3.....	62-3633.....	UTF53V10R Rod Assembly.....	1
4.....	101-7142.....	UTF53V10R 135/150 Rear End Spicer Bracket.....	1
5.....	101-7143.....	UTF53V10R 110/115 Rear End Spicer Bracket.....	1
6.....	201-0283.....	1/2"-13 x 2" Hex Head Bolt, Grade 8, ZP.....	2
7.....	201-0308.....	1/2"-20 x 1-1/4" Hex Head Bolt, Grade 8, ZP.....	2
8.....	201-0490.....	1/2"-13 x 3" Hex Head Bolt, Grade 8, ZP.....	1
9.....	201-0632.....	3/4"-16 x 3.5" Hex Head Bolt, Grade 5, ZP.....	2
10.....	201-0812.....	14MM-2MM x 80MM Hex Head Bolt, 10.9 HCS.....	1
11.....	201-0813.....	14MM-2MM x 50MM Hex Head Bolt, 10.9 HCS.....	2
12.....	201-0912.....	5/8"-18 x 2" Hex Head Bolt, Grade 8, ZP.....	2
13.....	202-0168.....	3/4"-16 Top Lock Nut, ZP.....	2
14.....	202-0184.....	1/2"-20 Jam Hex Nut.....	2
15.....	203-0007.....	3/4" Flat Washer, ZP.....	6
16.....	203-0012.....	1/2" Lock Washer, ZP.....	3
17.....	203-0013.....	5/8" Lock Washer, ZP.....	2
18.....	203-0106.....	5/8" SAE Flat Washer, ZP.....	2
19.....	203-0131.....	14MM Lock Washer, ZP.....	3
20.....	190-0155 (not shown).....	10"-5/8" Loom.....	1
21.....	290-0275 (not shown).....	7.6" 50LB Cable Tie.....	2
22.....	150-433 (not shown).....	.5ml Capsul 262 Threadlock.....	1



F-53 Chassis with 20-22K GVW Rear Bar

1. Position the vehicle on a level surface with the front wheels straight ahead and sitting at normal ride height. Set the brake and chock all the wheels.
2. Hold the axle bracket up to the rear end to locate the three (3) OEM bolts that line up to the bracket. Remove the OEM bolts and install the bracket to the rear end with the supplied bolts and lock washers. If the rear end had flat washers, reuse the washers in between the bracket and the rear end housing. Tighten all bolts.
3. Install the frame bracket and pinch plate on the frame rail. The frame must be between the pinch plate and frame bracket. The frame bracket is designed to mount to the bottom and the sides of the frame rail. Position the frame bracket below the frame rail on the passenger side in line with the axle bracket. Align the slotted holes in frame bracket with threaded holes in pinch plate. (Place the nut plate with lip facing down and towards the center of the vehicle). Install (2) 5/8"x2" fine threaded bolts, (2) 5/8" lock washers & (2) 5/8" flat washers. Tighten "just snug" for now.
4. Install the rod assembly onto the front of the axle bracket with one (1) 3/4"-16 x 3" bolt, four (4) 3/4" flat washers and a 3/4" lock nut. Put one (1) washer on the outside of the bushing and the other three (3) between the bushing and axle bracket. Position the frame bracket so it is straight with the axle bracket and rod assembly. Adjust the length of the rod assembly until you are able to pass a bolt thru both the rod assembly and frame bracket. Install a 3/4" bolt, flat washer and a 3/4" lock nut into the rod assembly and frame bracket. Be sure the flat washer is in between the urethane bushing and nut. Leave all bolts finger tight for now.
5. Once the frame bracket is straight with the rod assembly and axle bracket, alternately tighten down the 5/8" bolts on the frame bracket and torque to specifications. Then torque the 1/2"-20 x 1-1/4" bolts to the frame and tighten the jam nuts.
6. Torque the 3/4" bolts in the rod assembly to specifications. Inspect for any wiring or hoses that may rub against the brackets and secure in a safe position with the loom and/or cable ties provided.



Brazel's RV Performance
3912 Harrison Ave.

Centralia, Wa 98531

Phone: (360) 736-9494 • Fax: (360) 736-9497

www.brazelsrv.com